

EW-W

ELBOW

Without shoulder

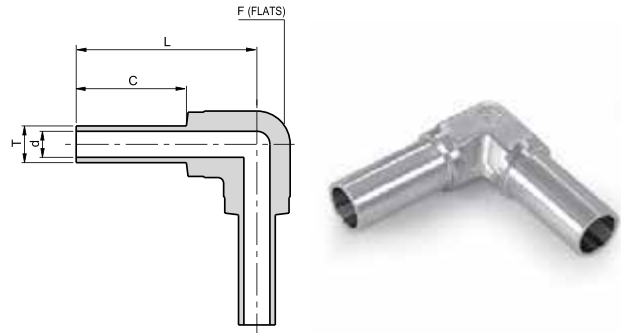

Ordering Information	L		C		d		F	T	W.T.	
	mm	inch	mm	inch	mm	inch	inch	inch/mm	mm	inch
P-EW-1/4-W	31.2	1.23	19.1	0.75	4.6	0.18	7/16	1/4"	-	0.035
P-EW-3/8-W	30.5	1.20	19.1	0.75	7.7	0.30	7/16	3/8"	-	0.035
P-EW-1/2-W	34.0	1.34	19.1	0.75	10.2	0.40	11/16	1/2"	-	0.049
P-EW-1/2-W W.T.=0.065	34.0	1.34	19.1	0.75	9.5	0.37	11/16	1/2"	-	0.065
P-EW-3/4-W W.T.=0.049	37.1	1.46	19.1	0.75	16.6	0.65	15/16	3/4"	-	0.049
P-EW-3/4-W W.T.=0.065	37.1	1.46	19.1	0.75	15.8	0.62	15/16	3/4"	-	0.065
P-EW-1-W W.T.=0.065	47.0	1.85	24.4	0.96	22.1	0.87	1 3/8	1"	-	0.065
P-EW-1-W W.T.=0.120	47.0	1.85	24.4	0.96	19.4	0.76	1 3/8	1"	-	0.120
P-EW-6M-W	31.2	1.23	19.1	0.75	4.0	0.16	7/16	6mm	1.00	-
P-EW-8MM-W	31.2	1.23	19.1	0.75	6.0	0.24	7/16	8mm	1.00	-
P-EW-10MM-W	34.0	1.34	19.1	0.75	8.0	0.31	11/16	10mm	1.00	-
P-EW-12MM-W	34.0	1.34	19.1	0.75	10.0	0.39	11/16	12mm	1.00	-

TW-W

TEE

Without shoulder

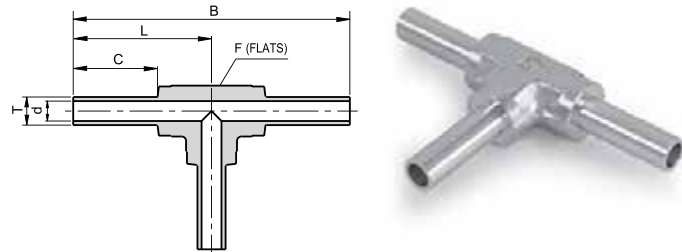

Ordering Information	L		B		C		d		F	T	W.T.	
	mm	inch	mm	inch	mm	inch	mm	inch	inch	inch/mm	mm	inch
P-TW-1/4-W	31.2	1.23	62.5	2.46	19.1	0.75	4.6	0.18	7/16	1/4"	-	0.035
P-TW-3/8-W	30.5	1.20	61.0	2.40	19.1	0.75	7.7	0.30	7/16	3/8"	-	0.035
P-TW-1/2-W	34.0	1.34	68.1	2.68	19.1	0.75	10.2	0.40	11/16	1/2"	-	0.049
P-TW-1/2-W W.T.=0.065	34.0	1.34	68.1	2.68	19.1	0.75	9.5	0.37	11/16	1/2"	-	0.065
P-TW-3/4-W W.T.=0.065	37.1	1.46	74.2	2.92	19.1	0.75	15.8	0.62	15/16	3/4"	-	0.065
P-TW-3/4-W W.T.=0.049	37.1	1.46	74.2	2.92	19.1	0.75	16.6	0.65	15/16	3/4"	-	0.049
P-TW-1-W W.T.=0.065	47.0	1.85	94.0	3.70	24.4	0.96	22.1	0.87	1 3/8	1"	-	0.065
P-TW-1-W W.T.=0.120	47.0	1.85	94.0	3.70	24.4	0.96	19.4	0.76	1 3/8	1"	-	0.120
P-TW-6MM-W	31.2	1.23	62.5	2.46	19.1	0.75	4.0	0.16	7/16	6mm	1.00	-
P-TW-8MM-W	31.2	1.23	62.5	2.46	19.1	0.75	6.0	0.24	7/16	8mm	1.00	-
P-TW-10MM-W	34.0	1.34	68.1	2.68	19.1	0.75	8.0	0.31	11/16	10mm	1.00	-
P-TW-12MM-W	34.0	1.34	68.1	2.68	19.1	0.75	10.0	0.39	11/16	12mm	1.00	-

Dimensions are for reference only, and are subject to change without notice.
 When ordering, be sure to add the Surface-Finish Designator (either H or E) to the Part Number. (See Material Table, page 157).